

Driver Manual

FS-8700-104 ControlNet B35 Driver

APPLICABILITY & EFFECTIVITY

Effective for all systems manufactured after April 2021.



Driver Revision: 1.02
Document Revision: 3.A



fieldserver

MSA Safety
1991 Tarob Court
Milpitas, CA 95035
Website: www.MSAsafety.com

U.S. Support Information:
+1 408 964-4443
+1 800 727-4377
Email: smc-support@msasafety.com

EMEA Support Information:
+31 33 808 0590
Email: smc-support.emea@msasafety.com

Contents

1	Description	4
2	Driver Scope of Supply	4
	2.1 Supplied by MSA Safety.....	4
	2.2 Additional Files Required.....	4
	2.3 Provided by the Supplier of 3 rd Party Equipment	4
	2.3.1 Required 3 rd Party Software	4
	2.3.2 Required 3 rd Party Configuration.....	4
3	Hardware Connections	5
	3.1 Hardware Connection Tips / Hints.....	5
4	Data Array Parameters	6
5	Server Side Configuration	7
	5.1 ControlNet Settings	7
	5.1 Server Side Connection Descriptions.....	7
	5.2 Server Side Node Parameters.....	8
	5.3 Server Side Map Descriptor Parameters.....	8
	5.3.1 FieldServer Specific Map Descriptor Parameters	8
	5.3.2 Driver Specific Map Descriptor Parameters	8
	5.4 Map Descriptor Example	9
6	Useful Features	10
	6.1 FieldServer LED Indicators.....	10
7	Vendor Information	11
	7.1 Using RSNetWorx Version 1.06 with PLC-5 Scanner.....	11
	7.2 Using RSLogix 5000 for Network Configuration.....	12
8	Reference	13
	8.1 Setting the FieldServer's ControlNet MAC ID	13
	8.2 Using the Network Access Port.....	13

1 Description

The FieldServer ControlNet B35 driver can be used to emulate a single slave station on a ControlNet network. ControlNet scanners can open a connection of up to 450 Bytes in each direction to the FieldServer. Data transfers are via Scheduled Communication and therefore the FieldServer has to be scheduled on the ControlNet network using a Network Configuration Tool such as RSNetWorx or RSLogix. The minimum supported network update time (NUT) is 5 MS. Connection to the ControlNet network is via two standard BNC connector ports. The connection may be to either one or both of the ControlNet ports. A connection to both ports provides dual redundant operation. A Network Access Port (NAP) is also provided for the temporary connection of a Network Configuration Tool.

Max Nodes Supported		
FieldServer Mode	Nodes	Comments
Server	1	The FieldServer can only emulate one ControlNet Slave station

2 Driver Scope of Supply

2.1 Supplied by MSA Safety

Part #	Description
FS-B3514-05	Anybus ControlNet Card
	Driver Manual

2.2 Additional Files Required

Filename	Comments
Config.csv ¹	Template loaded if no custom configuration ordered, otherwise Custom configuration loaded.
ControlNet EDS File	Required for working with Rockwell's RSNetworx Tool. Supplied with the FieldServer and also available via the following link: ControlNet EDS File .

2.3 Provided by the Supplier of 3rd Party Equipment

2.3.1 Required 3rd Party Software

RSNetWorx, RSLogix or another Network Scheduling Tool.

2.3.2 Required 3rd Party Configuration

Connection to a properly terminated ControlNet network.

¹ Loaded by FieldServer support.

3 Hardware Connections

The FieldServer is connected to the ControlNet network as shown in the connection drawing below.

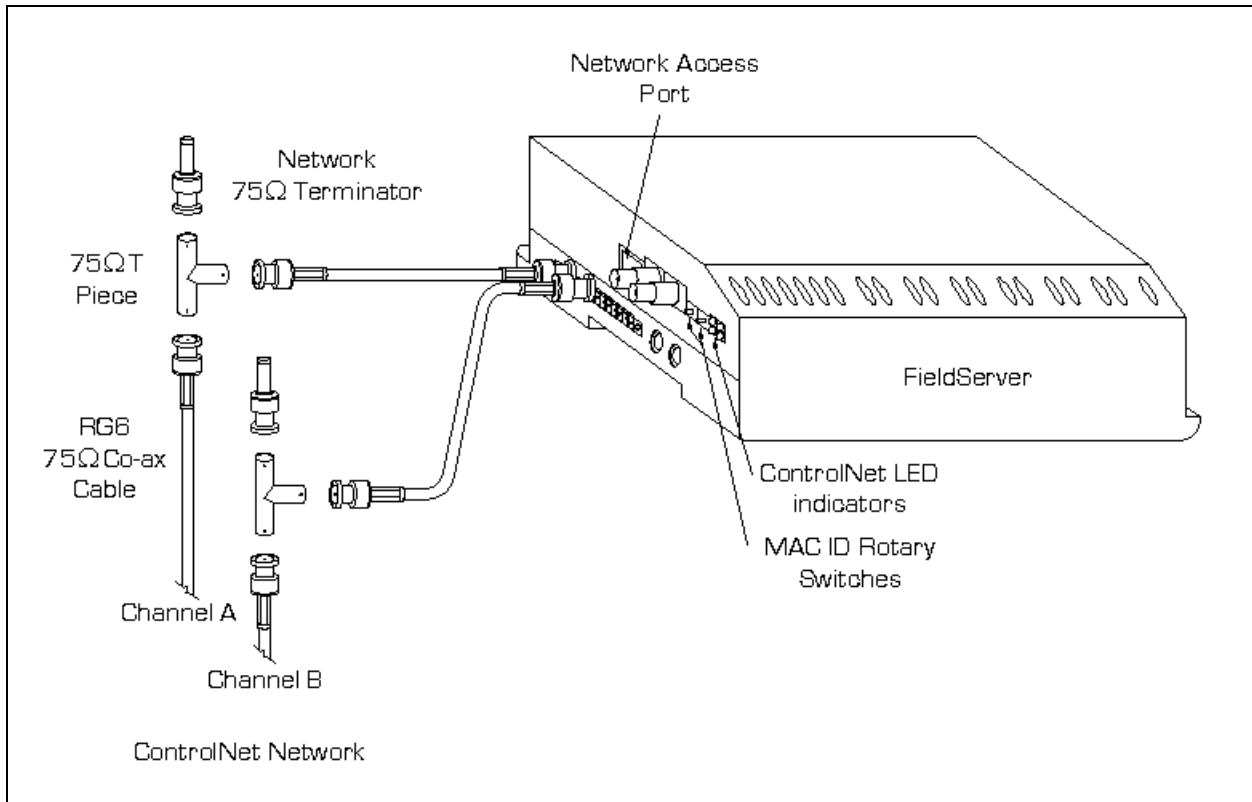

3.1 Hardware Connection Tips / Hints

Use the recommended network cable and terminators as specified by the ControlNet network organization and/or the manufacturer of your network equipment.

4 Data Array Parameters

Data Arrays are “protocol neutral” data buffers for storage of data to be passed between protocols. It is necessary to declare the data format of each of the Data Arrays to facilitate correct storage of the relevant data.

Section Title		
Data_Arrays		
Column Title	Function	Legal Values
Data_Array_Name	Provide name for Data Array.	Up to 15 alphanumeric characters
Data_Array_Format	Provide data format. Each Data Array can only take on one format.	Float, Bit, Byte, UInt16, UInt32, Sint16, Sint32
Data_Array_Length	Number of Data Objects. Must be larger than the data storage area required by the Map Descriptors for the data being placed in this array.	1-10000

Example

```
// Data Arrays
Data_Arrays
Data_Array_Name , Data_Array_Format , Data_Array_Length
DA_AI_01 , UInt16, , 200
DA_AO_01 , UInt16 , , 200
DA_DI_01 , Bit , , 200
DA_DO_01 , Bit , , 200
```

5 Server Side Configuration

For detailed information on FieldServer configuration, refer to the FieldServer Configuration Manual. The information that follows describes how to expand upon the factory defaults provided in the configuration files included with the FieldServer (see “.csv” files provided with the FieldServer).

This section documents and describes the parameters necessary for configuring the FieldServer to communicate with a ControlNet Client/Scanner.

The configuration file tells the FieldServer about its interfaces and the routing of data required. In order to enable the FieldServer for ControlNet communications, the driver independent FieldServer buffers need to be declared in the “Data Arrays” section, the FieldServer virtual node(s) needs to be declared in the “Server Side Nodes” section, and the data to be provided to the clients must be mapped in the “Server Side Map Descriptors” section. Details on how to do this can be found below.

NOTE: In the tables below, * indicates an optional parameter and bold legal values are defaults.

5.1 ControlNet Settings

Section Title		
FieldServer		
Column Title	Function	Legal Values
System_Station_Address*	ControlNet MAC ID of the FieldServer.	1-99

NOTE: The ControlNet MAC ID can also be set via the two rotary switches on the side of the FieldServer. These switches should be set to zero or to the same value as System_Station_Address in the configuration file. Alternatively, the System_Station_Address parameter should be eliminated from the configuration file. Failing to do so, will cause a warning LED to flash although the MAC ID from the configuration file will still be used.

Example

```
// FieldServer
FieldServer
Title          , System_Station_Address
CN_Test       , 5
```

5.1 Server Side Connection Descriptions

Section Title		
Connections		
Column Title	Function	Legal Values
Adapter	Adapter Name.	ControlNet

Example

```
// Client Side Connections
Connections
Adapter
ControlNet
```

5.2 Server Side Node Parameters

Section Title		
Nodes		
Column Title	Function	Legal Values
Node_Name	Provide name for node.	Up to 32 alphanumeric characters
Protocol	Specify protocol used.	X30_CNet_Slave

Example

```
// Server Side Nodes
Nodes
Node_Name , Protocol
CN5 , X30_CNet_Slave
```

5.3 Server Side Map Descriptor Parameters

5.3.1 FieldServer Specific Map Descriptor Parameters

Column Title	Function	Legal Values
Map_Descriptor_Name	Name of this Map Descriptor.	Up to 32 alphanumeric characters
Data_Array_Name	Name of Data Array where data is to be stored in the FieldServer.	One of the Data Array names from "Data Array" section above
Data_Array_Offset	Starting location in Data Array.	0 to maximum specified in "Data Array" section above
Function	Function of Server Map Descriptor.	RDBC – Reads data from the local input buffer WRBC – Writes data to the local output buffer

5.3.2 Driver Specific Map Descriptor Parameters

Column Title	Function	Legal Values
Node_Name	Name of Node to fetch data from.	One of the node names specified in "Server Node Descriptor" above
CNT_Data_Type	Data Type of local buffer.	Byte, Word, Dword, Bool
Address	Byte offset into local buffer.	RDBC: 0 – 449 WRBC: 4 – 453
Length	Number of CNT_Data_Type items in local buffer.	Byte: 1 – 450 Word: 1 – 225 Dword: 1 – 112 Bool: 1 – 3600

5.4 Map Descriptor Example

```
// Server Side Map Descriptors
Map_Descriptorss
Map_Descriptor_Name , Data_Array_Name , Data_Array_Offset , Function , Node_Name , CNT_Data_Type
Get_Data           , Input_Data       , 0                , Rdbc   , CN5     , WORD
Put_Data           , Output_Data      , 0                , Wrbc   , CN5     , WORD
```

	Address	Length	Scan_Interval
	0	225	1s
	4	225	1s

Rdbc - Read function map descriptor gets data from the ControlNet network and stores it in the Input_Data data array.

Wrbc - Write function map descriptor puts data from the Output_Data data array onto the ControlNet network.

NOTE: The start address for the output buffer is 4. Addresses 0-3 are not available.

NOTE: Each address refers to an individual local input and output buffer. Each buffer can contain up to 450 bytes.

6 Useful Features

6.1 FieldServer LED Indicators

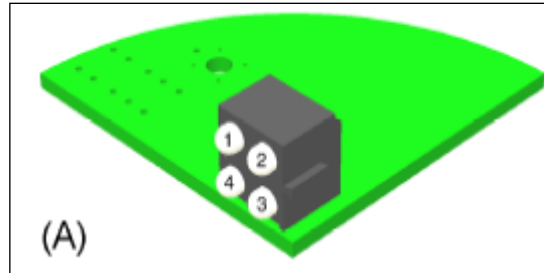

LED 1 – Module Status

Color	Frequency	Description
Green	Flashing	Module is waiting for initialization
Green	Steady on	Module is initialized
Red	Flashing	Minor fault, MacID has been changed after initialization, etc.
Red	Steady on	Major fault, module must be restarted

LED 2 – LED Channel A

Color	Frequency	Description
Red/Green	-	See Channel LEDs below

LED 3 – LED Channel B

Color	Frequency	Description
Red/Green	-	See Channel LEDs below

LED 4 – Module Owned

Color	Frequency	Description
Green	Steady on	A connection is opened against the ControlNet module
Off	-	No connection is opened

Channel LEDs

Channel LEDs	Description
A and B, steady off	Module is not initialized
A and B, steady red	Faulted unit, must be restarted or repaired
A and B, alternating red/green	Selftest of bus controller
A and B, flashing red	Incorrect node configuration, duplicate MacID, etc.
A or B, steady off	Channel is disabled, depending on network configuration
A or B, steady green	Normal operation of channel
A or B, flashing green	Temporary errors (node will self-correct) or node is not configured to go online
A or B, flashing red	Media fault or no other nodes on the network
A or B, flashing red/green	Incorrect network configuration

7 Vendor Information

7.1 Using RSNetWorx Version 1.06 with PLC-5 Scanner

The Anybus ControlNet module is not supported for versions earlier than 1.06.

- Ensure all nodes are physically connected and start RSNetworx.
- Go online (check the Go online box) - all connected nodes should appear on the screen.
- Right click on the PLC5 node and choose ControlNet configuration. The program now launches the Map Editing Tool used to set up data mapping in the PLC-5 processor.
- Right click on the line that contains the Anybus ControlNet module (in the current version of RSNetworx displayed as Any-BusDT) and choose Insert device connection.
- When the line changes to blue, the connection size in, connection size out and to which address in the PLC the data shall be mapped should be entered. The data is mapped to the Integer area (N-area). For example, 50 bytes in each direction can be mapped so now 25 words in and 25 words out can be chosen.
- Save the configuration, switch the PLC key to run and the data is transferred to/from the PLC data table at the specified address.

7.2 Using RSLogix 5000 for Network Configuration

RSLogix is a programming and configuration tool from Rockwell automation. The information included in this section is based on an entry in the Rockwell Automation Support Library and can be accessed at:

www5.software.rockwell.com/support/knowledge.nsf/9dc47c2a86607f2d86256365001169f5/bb01b77898478eca852568ef005e0b52?OpenDocument

RSLogix 5000 Version 2.25 and higher versions have a generic profile called CONTROLNET-MODULE which is applicable to devices that connect directly to ControlNet, such as the 1203-CN1 communications card with a Rockwell drive or a Schneider Momentum I/O device. The Anybus ControlNet card also uses this profile. All Anybus ControlNet-enabled I/O will use the same assembly instance numbers, but the data size will change depending on the application and must be relayed to the end user. The ControlNet module does not use configuration data so the length should be left at zero, though a non-zero number must be entered for the assembly instance. The following list provides information on the settings for the CONTROLNET-MODULE profile with AnyBus-S enabled devices.

Name:	(choose a unique name for this module)
Description:	(self-explanatory and optional)
Comm Format:	Select 'Data - INT'
Node:	Select the ControlNet node number for this device
Input Assembly Instance:	100
Size:	1-225
Output Assembly Instance:	150
Size:	Varies with how the module is initialized
Configuration Assembly Instance:	1
Size:	0

NOTES:

- The ControlNet module uses a ControlNet 32-bit run/idle header, so the actual data from the module will always start with word 2 (the third word) of the data. The first 2 words, at 16 bits each, are the ControlNet run/idle header. To mask off the run/idle header for clarity, create a user defined type with 2 members - HEADER, type DINT; and DATA, type INT with 'input assembly size - 2'. Copy the data from the actual input tag to a tag of this structure, and then reference the structure's DATA member using the element numbers in your documentation.
- There will always be a configuration tag of type AB:ControlNet_MODULE:C:0 created for this module, which has one member called Data, of type SINT[400]. This SINT[400] tag is created regardless of the configuration size, which can range from 0 to 400 bytes (SINTs). Since a data size of zero is specified, no data will be sent to the module.

8 Reference

8.1 Setting the FieldServer's ControlNet MAC ID

The MAC ID can be set in the FieldServer's CSV file using the `System_Station_Address`, (refer to **Section 5.1**), or it can be set with the two rotary switches as indicated on the connection diagram. The left switch selects the left decimal digit and the right switch the right decimal digit of the MAC ID.

Note that the software setting with the `System_Station_Address` overrides the hardware setting with the rotary switches. Set the rotary switches to zero or to the same value as in the `System_Station_Address` to prevent the warning LED from flashing. A mismatch will still result in the software setting being used.

8.2 Using the Network Access Port

The Network Access Port (NAP) should only be used temporarily to connect a network configuration tool. It must not be used to connect to the main ControlNet network.